

UNIT 10
COMMUNICATION SYSTEMS

Section-A

Very Short Answer Question

[1-Mark]

1. Sky wave transmission of electromagnetic wave cannot be used for TV transmission why?

TV transmission takes place at higher frequencies (approx 18 MHz to 200 MHz). Such higher frequencies do not return back to the earth.

2. To send audio signal over long distance, carrier wave of higher frequency is used. Why?

Higher frequency carrier wave provides wider bandwidth.

3. In digital communication, PCM (Pulse Code Modulation) is preferred than PAM (Pulse Amplitude Modulation). Justify your comment.

- (i) PCM is free from noise in interfering signals. It is also coded electrical signal.
- (ii) It permits use of repeater for long distance transmission.

4. In sending a binary data over an analog transmission line, what kind of device does the conversion?

MODEM

5. For what kind of signal would you use for encoding and decoding process?

Pulse Code Modulation -PCM is free from noise in interfering signals

6. When a teacher lectures in the class, is the classroom a full duplex communication system or a half duplex communication system?

In the full duplex mode, transmissions are possible in both directions simultaneously. A standard telephone system is an example of full-duplex transmission.

7. Your wireless notebook computer works on one desk, but when you move it to a nearby desk, you cannot receive a signal. What may be happening? How might you fix the problem?

By increasing the frequency range.(wide Band width)

8. Express the following I.P address in binary:

128.171.17.13

Hint: 128 is 10000000.

9. Convert the following address in binary to decimal notation:

11110000 10101010 00001111 11100011

Hint: 11110000 is 240 in decimal.

10. A tester shows that a UTP (Unshielded Twisted Pair) cord has too much cross-stalk interference. Why?

A standard UTP cord contains 4 wire pairs. The pairs in the bundle will radiate some of the energy producing electromagnetic (EM) interference in other pairs. This mutual EMI among the wire pairs in UTP cord is called cross-stalk interference. The twisting of each pair normally keeps cross-stalk interference to a reasonable level.

Installer must be careful not to untwist the wire more than 1.2cm, when adding connectors. This limit will not eliminate terminal cross-stalk interference but it should limit to an acceptable level.

11. How do we make television broadcasts for larger coverage and for long distance?

By using (i) tall antennas which is familiar landmark in many cities and (ii) using artificial satellites —called geostationary satellites. Since television signals are of high frequency and are not reflected by ionosphere so we use satellites to get them reflected & transmission of TV signals can be used for larger coverage as well as for long distance.

12. As we know parallel transmission is faster than serial transmission. Name the device which converts parallel to serial transmission.

Multiplexer

13. In normal radio operation how does channel bandwidth usually related to bandwidth required to transmit a data stream of a given speed.

If you want to transmit at a given bit rate, you will need a channel whose bandwidth is sufficiently wide. Multiplexer is used to convert serial transmission into parallel.

14. Optical Radio telescopes are built on ground but X-Rays telescopes are possible only from satellites orbiting earth. Why?

Atmosphere absorbs X-rays while visible and radio waves can penetrate it.

15. Do you think P2P architectures will be popular in the future .Why?

Peer to peer communication applications are likely to appear in near future offering a much broader spectrum of services.

16. Scientists put x-ray astronomical telescope on the artificial satellite orbiting above the earth's atmosphere whereas they build optical and radio-telescopes on the surface of the earth. Why ?

X-rays have very high frequency and much smaller wavelength. These rays get absorbed by the earth's atmosphere. On the other hand, optical (visible) radiations and radio-waves can pass through the atmosphere. That is why optical and radio telescopes can be installed on the earth's surface.

17. In TV transmission which is used –either A.M or F.M?

In TV transmission FM is used for Sound signal and AM for picture signal.

18. In demodulation stage , how the RF signal is removed from AF?

Rectifier is used to rectify the modulated wave (i.e) negative half of the modulated wave is eliminated. It separates the audio signal from the carrier wave.

19) In the transmission of television signals sky waves are not used Give reason?

The television signals have frequencies in 100-200 MHz range. As ionosphere cannot reflect radio waves of frequency greater than 40 M back to earth, the sky waves cannot be used in the transmission of TV signals.

20) 'F2 layer' plays an important role in communication. Why?

F2 is the top most layer of ionosphere. Its height is 240-400 Km in day time where as at night it falls from 400-300Km. It is very thick layer and most of its molecules are ionized. It is the most useful reflecting layer for high frequency radio waves.

21) The strength of received signal is almost constant in the receiving stage. How can you achieve this?

AGC stands for Automatic Gain Control. It is used in receiver so that the strength of received signal is almost constant.

22) In satellite communication, how transponder helps as to Uplink and down link signals?

In satellite communication, uplink signals are transmitted from earth stations. The transponder receives these signals, convert them to different frequencies and retransmits them to back to earth as downlink signals.

23) Is it velocity factor of a cable is the ratio of reduction of speed of light? Give comment.

Velocity factor (VF) of a cable is the ratio of reduction speed of light in the dielectric of the cable. Velocity of light in vacuum is 3×10^8 m/sec. It reduces when light passes through a medium. Velocity of light in a medium is given by

$$v = c / \sqrt{k} \quad \& \quad \text{where, } c - \text{velocity of light in vacuum and} \\ k - \text{is the dielectric constant of the medium}$$

$$Vf. = v/c = 1/\sqrt{k}$$

For a line velocity factor is generally of the order of 0.6 to 0.9.

24) Why is delta modulation a convenient method of digital modulation.

Delta modulation involves simple pulse coding and decoding methods. A simple delta modulation uses just one bit per sample i.e. a 'non-zero' sample or one per sample. Thus, this method is convenient to use.

25. In an optical fibre why the glass fibres have high refractive index as compare to thin layer of coating on it?

The optical fibres are normally made of glass of high refractive index coated with a thin layer of glass of low refractive index to provide a suitable boundary. If this is not done the phenomenon of total internal reflection is not possible inside the optical fibre or the light would pass from one fibre to another fibre.

26. What is necessary for full duplex operation using a two wire circuit? Give an example of full-duplex transmission.

In the full duplex mode, transmissions are possible in both directions simultaneously but they must be between the same two stations. A standard telephone system is an example of full-duplex transmission.

27. Give any two necessary conditions for the stimulated action of LASER to take place.

- (i) Photons of light of the right frequency must strike the atoms of the laser medium in large numbers.
- (ii) The number of atoms in the excited state must be larger than that in the ground state — population inversion.

28. What is necessary for full duplex operation using a two wire circuit? Give an example of full-duplex transmission.

In the full duplex mode, transmissions are possible in both directions simultaneously but they must be between the same two stations. A standard telephone system is an example of full-duplex transmission.

29) Why does the electrical conductivity of earth's atmosphere increase with altitude? Atmospheric pressure decreases with increase in altitude. The high energy particles (ie & rays and cosmic rays) coming from outer space and entering our earth's atmosphere cause ionization of the atoms of the gases present there. The ionizing power of these radiation decreases rapidly as they approach the earth. due to decrease in number of collision with the gas atoms. It is due to this reason that the electrical conductivity of earth's atmosphere increases with altitude

30) If you want transmit an audio signal for long distance, How it can be made possible?

1. The length of the antenna required is so large ($L = 5000\text{m}$) that is practically impossible to set up it.
- 2 The energy radiated from the antenna in audio frequency range is Practically zero
- 3 The audio signals transmitted from the different broadcasting stations will get inseparably mixed.

31) MUF helps us to receive signal by the application of ionosphere. How it helps us? Maximum usable frequency (MUF) is defined as the highest frequency that is returned to the earth by the considered layer of the ionosphere after having been beamed at some angle with the normal

$$\text{MUF} = \text{C.F.} \frac{\sec\theta}{\cos\theta}$$

where C.F. is the critical frequency as defined as the highest frequency that is returned to the earth by the considered layer of the ionosphere after having been sent straight (normally) to it. 'θ' is the angle between the normal and the incident ray.

32) Numerical aperture depends upon diameter of the core. Give reason?

Refractive index μ of core of optical fibre is slightly higher than glass cladding. Light propagates through and along the fibre by the series of bounces caused by internal reflection at the interface of the core and cladding. For total internal reflection the light should enter the fibre at an angle θ in accordance with core of acceptance angle θ_c

$$\text{NA} = \sin\theta_c = \sqrt{(\mu_1^2 - \mu_2^2)}$$

Numerical aperture depends upon diameter of the core It decreases as the diameter of core decreases vice versa

33) Draw the wave form for (i) PAM and (ii) PPM. Explain

i) Pulse Amplitude Modulation : Amplitude of the pulse varies in accordance with the modulating signal.

Sending: When A sends to B, A encrypts with B's Public key. When B sends to A, B encrypts with A's public key. **Receiving:** In turn when B sends to A, A decrypts with A's private key.

40. When a packet arrived from the Internet a firm filters them with an application firewall and then passes them to an IPsec Server operating in tunnel mode. The application firewall is designed to protect against e-mail viruses, what is wrong with this setup?

Trojan Horse software on their machine by operating up e-mail attachments. In general the strongest policies mean nothing if users do not follow them so policy implementations must include sanction for employees who violate security policies.

41. Give representative frequency of uplink and downlink communication.

C- Band satellites uses frequency of above 6GHz for uplink and 4GHz for downlink . KV-Band satellite uses frequency of 14Ghz for uplink and 12GHz for downlink.

Ka-Band has uplink frequency of 30GHz and downlink frequency of 20GHz.

42. Line of sight communication (LOS) is good for only 30-50Km and losing required LOS connection. Why? How to solve the problem in microwave communication.

Microwave system can travel only a limited distance before problems occur. Signals may grow too weak because of attenuation. The receiver might be so far away that target falls below the horizon. Losing the LOS or their may be obstacles between dishes. Microwave systems use repeaters to solve this problem. They capture and regenerate the signal to remove the propagation effects before passing it to the receiving antenna.

43. In optical fiber refractive index of cladding is less than core. Why?

It helps to undergo multiple total internal reflections through the optical fiber.

44. "A RADAR using a wave length 5cm and having an antenna disc of diameter 10m has an angular resolution smaller than 0.01 radian." Is this statement correct?

Angular resolution = $5 \times 10^{-2} / 10 = 0.005$ rad, which is less than 0.01 rad. So given statement is correct.

45. If one bit is "1" another bit is a "1". What will be the result of XOR operation . What if both bits are "0"? Draw suitable wave form?

A	B	Y	Y —
0	0	0	1
0	1	1	0
1	0	1	0
1	1	1	0

46. How do you think TCP/IP standards will have to change in future to continue to improve internet?

TCP/IP layers govern transmission of data across the internet ensuring that any two host computers can communicate . It is dominant in corporate networking .

47. An AM wave is represented by $C_m(t) = 6 (1 + 0.5 \cos 12560t) \cos 22 \times 10^5 t$. Calculate:

Amplitude and frequency of carrier, Modulation Index , Maximum and Minimum amplitude of the AM wave.

48. Using Internet , How can you transfer a file or software from one computer to another. Explain.

File Transfer Protocol(FTP)

49. You are preparing your website , how can you utilize HTML and http for designing and uploading a file ?

HTML(Hypertext markup language) – used to design the webpage.

http:(Hypertext transfer Protocol) – used to transfer the file from server to client.

50. When a station sends a message to its mail host,

a) what standard does it use ?

b) when sender's mail host sends the message to the receiver's mail host , what standard does it use.

c) when the receiver's e-mail client downloads new mail from its mail host, what standard is it most likely to use ?

There are two modes .Point to point (p2p) and broadcast.

In P2P ,communications takes place between one one to one.

In broad communication takes place between one to many.

51. For better quality of music transmission FM is preferred .Why?

FM gives better quality transmission and has a larger band with . It is in the form of frequency variation , therefore man made noise do little harm .So it is preferred for transmission of music(FM radio-88 to108 MHz)

52. You are trying to connect your computers over a network. In this how can you use DCE and DTE devices to establish the network?

DCE (Data Communications Equipment) : It creates a physical connection between the source and destination computers over a network.

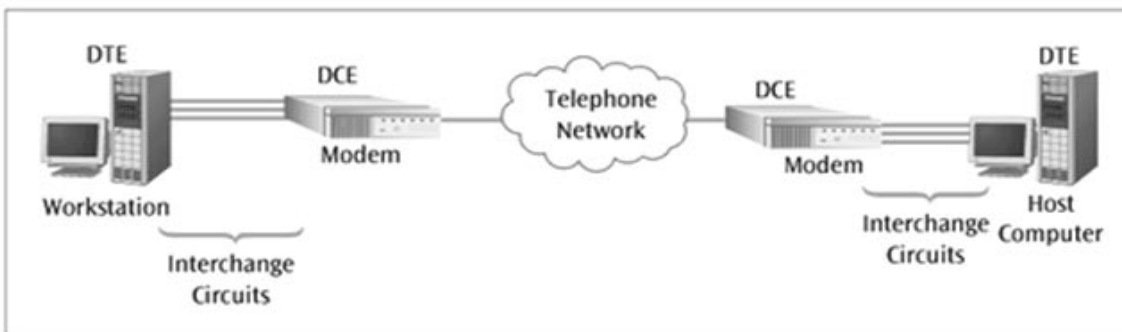

DTE (Data terminal Equipment) : It connects computers to a WAN with the help of a DCE . DTE is end –user equipment , such as a router or computer

53) A TV. tower has a height of 100m . How much population is covered by the TV. broadcaste if the average population density around the tower is $1000/\text{km}^2$

Ans :- Here $h = 100\text{m}$

$$R = 6400\text{km}$$

$$\text{Population density} = 1000$$

$$d = \sqrt{2hR}$$

$$d = \sqrt{2 \times 0.1 \times 6400}$$

$$= \sqrt{1280} \text{ km}$$

$$\text{Area covered by broadcast, } A = \pi d^2 = 3.14 \times 1280$$

$$= 3919.2 \text{ km}^2$$

$$\text{population covered} = \text{Area} \times \text{population density}$$

$$= 3919.2 \times 1000 = 3919200$$

54) Total internal reflection is the back bone of optical communication . Explain.

Modern optical fibre are formed by two layers of glass . The fibre core (8 is surrounded by a concentric of lower index glass known as cladding. The total internal reflection occurs at the core-cladding interface In fibres designed for high speed telecommunications the core is only a few microns in diameter not much larger than the wavelength of the light used. The refractive index of a typical strand is 1.7 and the refractive index of the material coated over it is 1.5

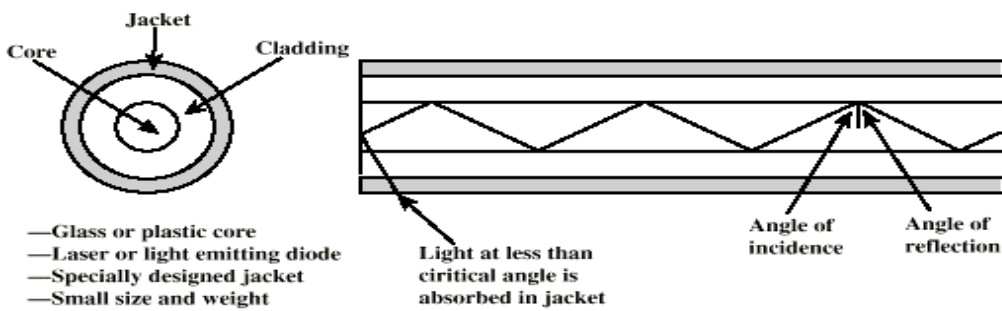

55) Modem helps us to connect WAN network ? Explain?

Modem is a device that can connect one computer to another across ordinary telephone lines . The current telephone system cannot carry the voltage changes required for a direct digital connection . A modem overcomes this limitations by (i) modulating digital information into audio tones for transmission across the phone line .(ii) demodulating the audio tones back into digital information upon reception. It is from these actions (modulate and demodulate) that the name modem is derived.

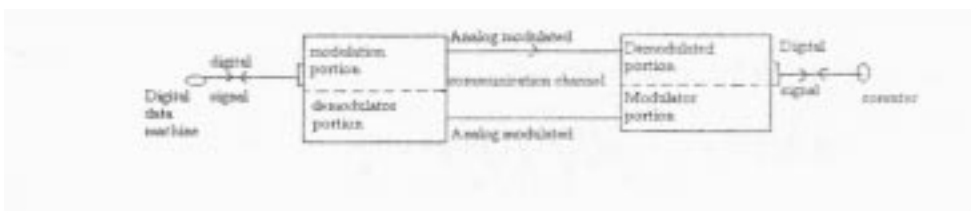

56) Electronic reproduction of a document at a distant place is possible by FAX.How is coding and decoding made possible using FAX?

telegraphy or FAX.

A FAX machine

(1) digitizes printed images and transmits the corresponding data over the telephone lines.

(ii) receives digital image information placed on the network, and reconstruct the received image on the paper thus to send the document through FAX.

Explain the Functions fo FAX.(a) At the sending end, there is some sort of sensor (optical scanner) to read the paper.

- (b) There is some standard way to encode the white and black spots that the fax machine observes on the paper, so that they can travel through the phone line.
- (c) At the receiving end there is a mechanism that marks the paper with white and black spots to reproduce the document
- (d) The printer in the FAX machine prints these digital pulses faithfully in the form of dots to build up a facsimile copy of the original

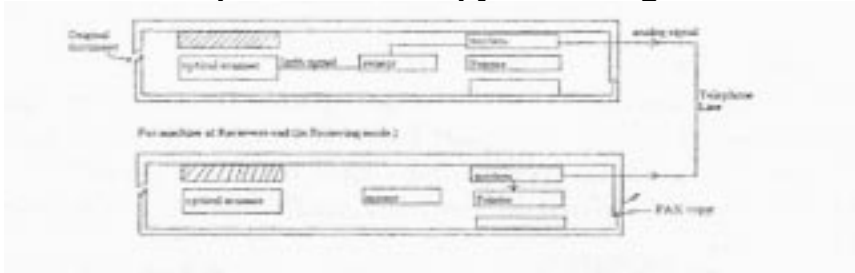

57) With the help of diagrams explain the difference between amplitude modulation and frequency modulation.

Amplitude modulation:- In this type of modulation the amplitude of the carrier signal wave varies in accordance with the modulating signal, but in frequency modulation frequency of carrier wave varies.

Diagrams below show the types of modulation.

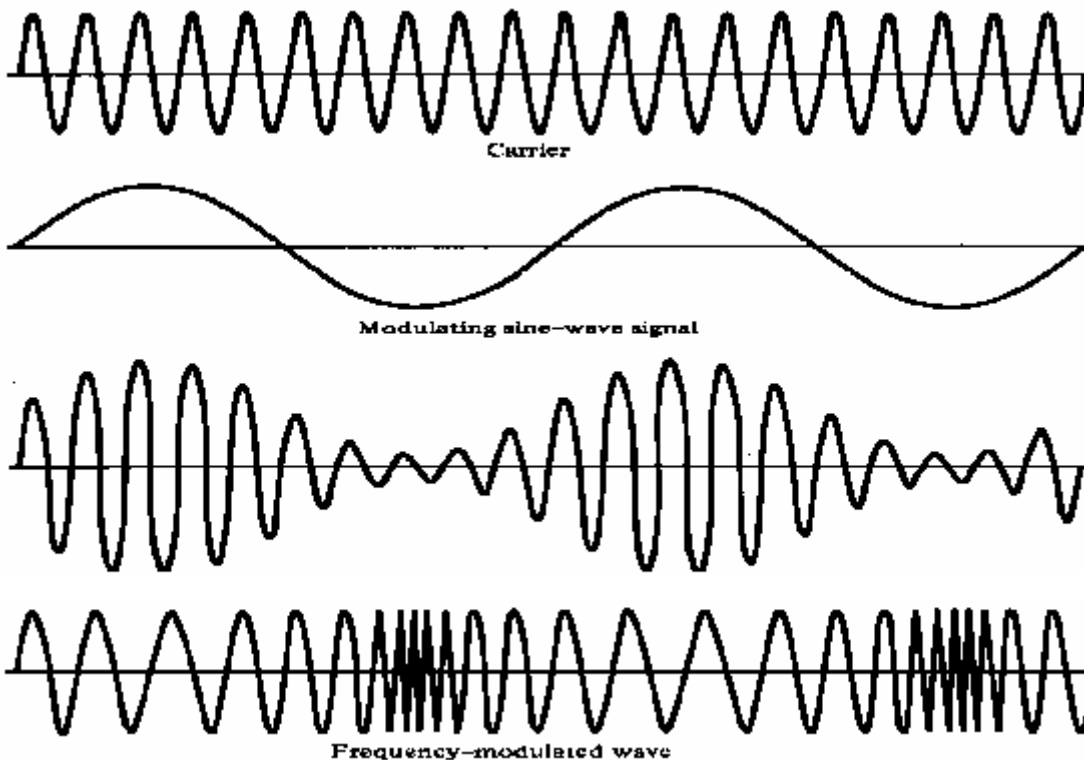

58) How will you find the range of the receiving antenna using line of sight communication.

The transmitted wave traveling in a straight line, directly reach the receiver and are then picked up by the receiving antennae. It can be seen that due to the final curvature of the earth such a wave cannot be seen beyond the tangent point R_1 and R_2 . Suppose height of the is h and the radius of earth is r (that is $OR_1 = OR_2 = OP = r$). In the right-angled triangles OQR_1 , QPR_1

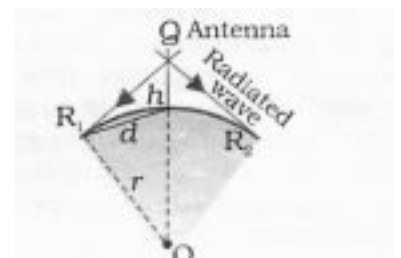

we have

$$OQ^2 = QR_1^2 + OR_1^2$$

$$QR_1^2 = h^2 + d^2$$

Then

$$(r+h)^2 = r^2 + d^2 + h^2$$

$$r^2 + h^2 + 2hr = r^2 + d^2 + h^2$$

$$d^2 = 2rh$$

$$d = \sqrt{2rh}$$

59. Ground receiver station is receiving a signal at (i) 5MHz and (ii) 100MHz transmitted from a round transmitter at a height of 300 m, located at a distance of 100 km from the receiver station. Identify whether the signal is coming via space wave or sky wave propagation or satellite transponder. Radius of earth = 6.4×10^6 m. N_{max} of the Isosphere = 10^{12} m^3

Maximum distance covered by space wave communication = $\sqrt{2Rh} = 62 \text{ km}$

Critical frequency $f_c = 9 \times N_{max}^{1/2} = 9 \text{ MHz}$

(i) 5 MHz $< f_c$ sky wave propagation (ionospheric propagation).

(ii) 100 MHz $> f_c$ satellite mode of communication.

60. Explain how the data transmission and reception take place using optical communication.

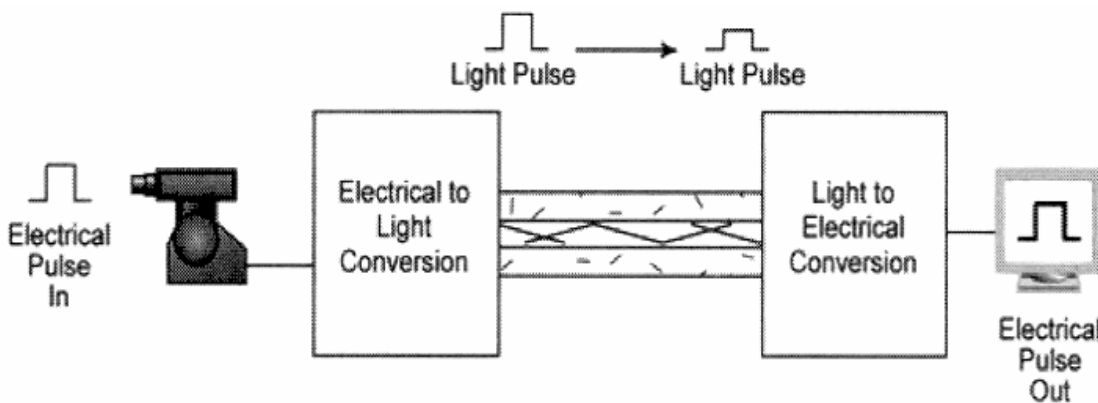

Optical communication is based on the phenomenon of total internal reflection. When the light travels from the optically denser medium to optically rarer medium at an angle greater than critical medium the light get reflected in the same medium.

61) In amplitude modulation, what is the role of LSB and USB. Draw a suitable diagram

$$e = E_c \cos w_c t + \frac{1}{2}(m a E_c \cos(w_c + w_m) + m a E_c \cos(w_c - w_m)) \dots \dots (7)$$

eq (7) indicates the following

ii. The process of amplitude modulation does not change the original carrier frequency but produces two new frequencies ($v_c + v_m$) and ($v_c - v_m$) known as side band frequencies

ii. ($v_c + v_m$) is called upperside band frequency(USB) ($v_c - v_m$) is known as lowerside band frequencies (LSB).

iv. The band width requires for A.M. is twice the frequency of the modulating signal.

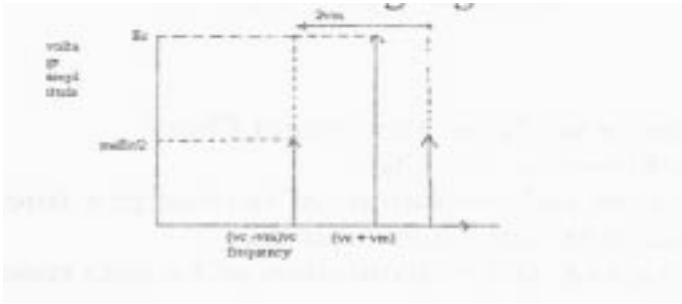

62. Explain the essential devices used for optical communication

In optical communication two essential devices are

1. Optical source to generate a beam of light
2. Optical detector to collect light pulses effectively.

Two photonic devices used to generate a beam of light are light emitting diodes (LED's) and laser

Light emitting diode (LED). In a P-N junction diode there is a potential barrier across the depletion region on both sides of P-N junction.

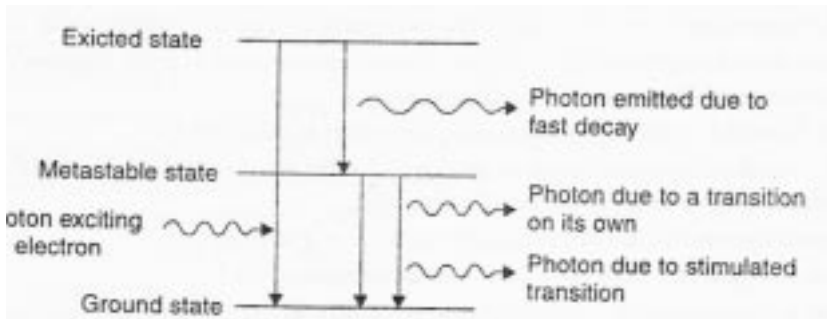
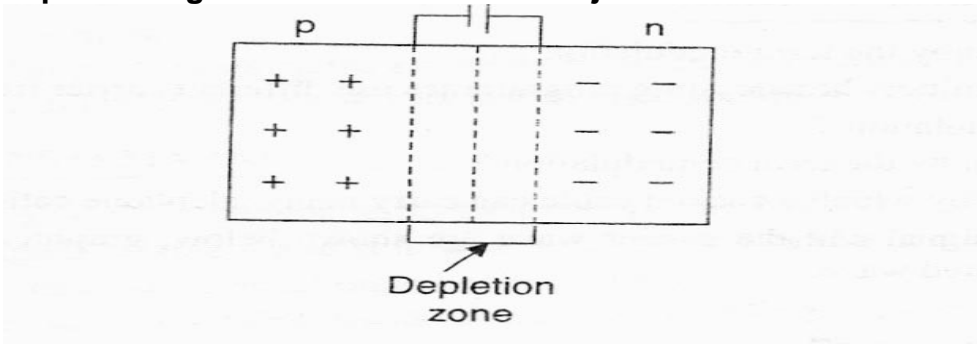

Laser diode : semiconductor gallium arsenide (GaAs) is used in the manufacturing P-N junction laser diode.

63) Draw a block diagram of data transmission and a data receiver. Explain

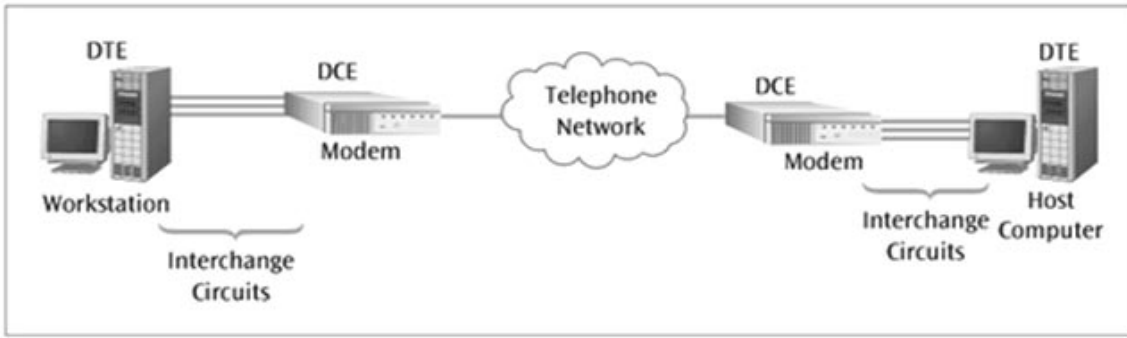

64. Data transmission and reception take place using Modem. In this what is the role MODEM and the network layer?

The name modem is a contraction of the terms Modulator and Demodulator (MODEM). Both the functions are included in a single unit. Modems are placed at both ends of the communication circuit.

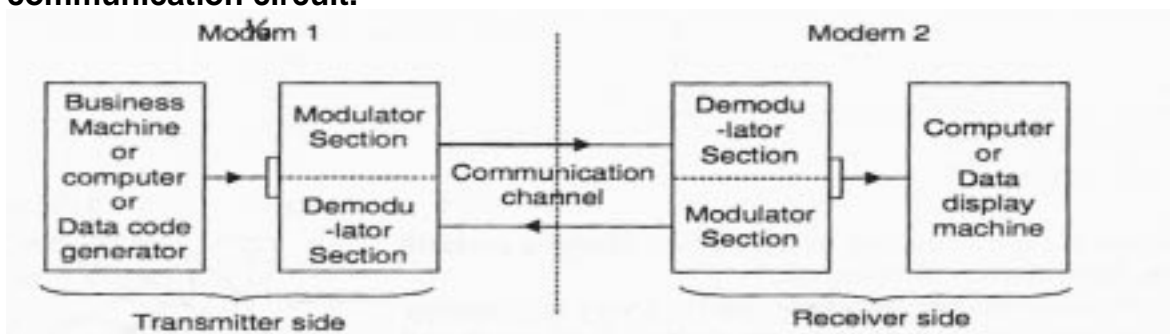

At the transmitting station modem changes digital output from a computer or any other business machine to a form, which is compatible with communication channel. Modem converts digital data to analog signals for use in modulating a carrier signal (FSK or PSK). At the receiver end of the system, the carrier is demodulated to recover the data.

65. A schematic arrangement for transmitting a message signal (20 Hz to 20kHz) is given below:

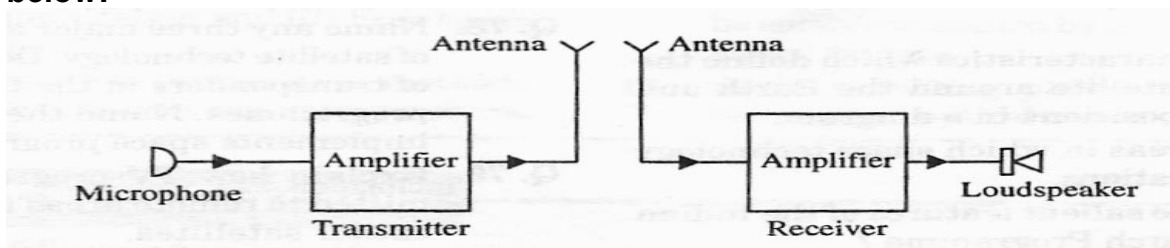

Give two drawbacks from which this arrangement suffers. Describe briefly with the help of a block diagram the alternative arrangement for the transmission and reception of the message signal.

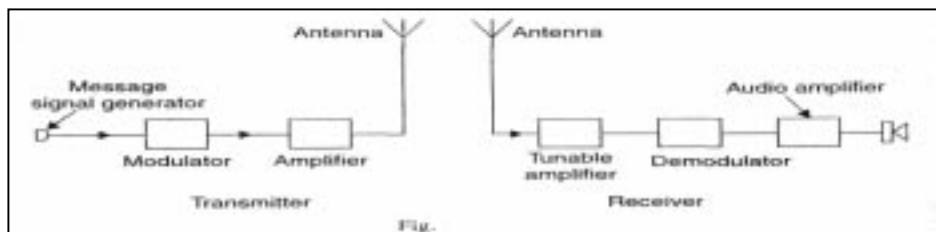

TRANSMITTING STAGE

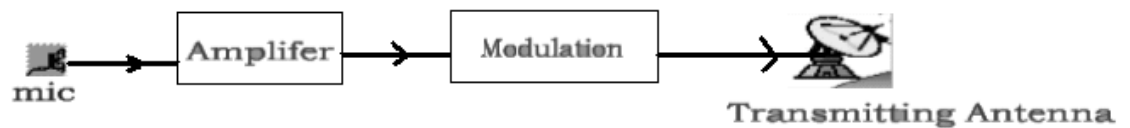

● RECEPTION STAGE - RECEIVER

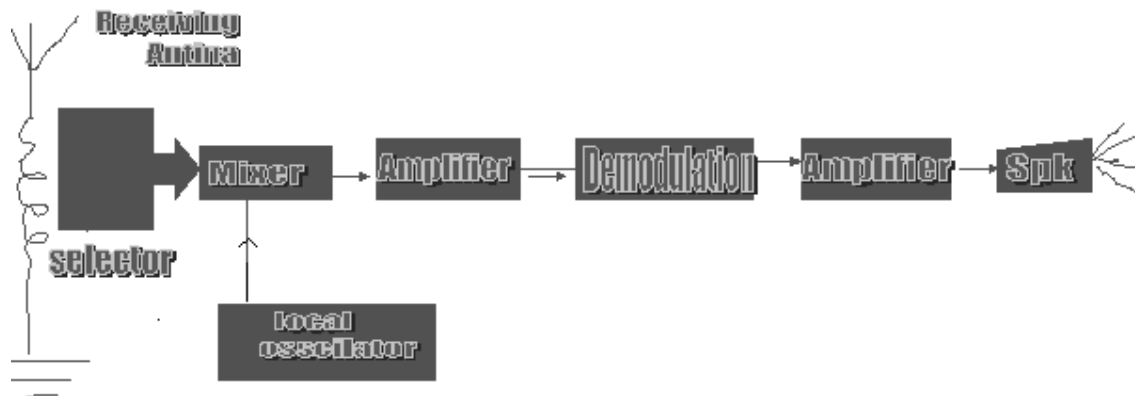

Two drawbacks of the given arrangement are:

- (1) Audio signals cannot be efficiently radiated and do not propagate well in space.
- (2) Simultaneous transmission of signals by different transmitters can cause confusion at the receiver end due to overlapping of frequencies.

66. The maximum peak-to-peak voltage of an AM wave is 16mV and the minimum peak-to peak voltage is 4mV. Calculate the modulation factor.

Maximum voltage of AM wave,

$$V_{\max} = \frac{16}{2} = 8\text{mV}$$

Minimum voltage of AM wave,

$$V_{\min} = \frac{4}{2} = 2\text{mV}$$

$$m_a = \frac{V_{\max} - V_{\min}}{V_{\max} + V_{\min}}$$

$$= \frac{8-2}{8+2} = \frac{6}{10} = 0.6$$

67. An AM wave is represented by the expression: $v = 5(1+0.6\cos 6280t) \sin 221 \times 10^4 t$ volts

- (i) What are the maximum and minimum amplitudes of the AM wave.
- (ii) What frequency components are contained in the modulated wave.

The AM wave equation is given by ;

$$v = 5(1+0.6\cos 6280t) \sin 221 \times 10^4 t \text{ volts} \dots\dots\dots(i)$$

(i) Maximum amplitude of AM wave
 $= E_C + m_a E_C = 5 + 0.6 \times 5 = 8V$

Minimum amplitude of AM wave
 $= E_C - m_a E_C = 5 - 0.6 \times 5 = 2V$

(ii) The AM wave will contain three frequency viz

$f_c - f_s,$	$f_c,$	$f_c + f_s$
336-1	336	336+1
335kHz	336kHz	337kHz

68. An audio signal of 1 kHz is used to modulate a carrier of 500 kHz. Determine

(i) Sideband frequency, (ii) Bandwidth required.

Carrier frequency, $f_c = 500$ kHz

Signal frequency, $f_s = 1$ kHz

(i) The AM wave has sideband frequency of $(f_c + f_s)$ and $(f_c - f_s)$.
 501 kHz and 499 kHz

(ii) Bandwidth required = 499 kHz to 501 kHz = 2 kHz

69. The TV transmission tower at a particular place has a height of 160m. What is its coverage range? By how much should the height be increased to double its coverage range? Given that radius of earth = 6400 km.

Here $R = 6400\text{km} = 6400 \times 10^3 \text{ m}$
 $h = 160\text{m}$

Therefore

$$d = (2 \times 6400 \times 10^3 \times 160)^{1/2} = 45255\text{m}$$

Coverage range, $d = (2Rh)^{1/2}$

For the first case

$$\frac{h_2}{h_1} = \frac{d_2^2}{d_1^2} = (2)^2 = 4$$

$$h_2 = 4h_1 = 4 \times 160 = 640\text{m}$$

70. A TV tower has a height of 110m. How much population is covered by the TV broadcast if the average population density around the tower is 1000 km^{-2} ? Given that radius of Earth = $6.4 \times 10^6 \text{ m}$.

Radius of the area covered by TV broadcast is

$$d = (2Rh)^{1/2}$$

$$R = 6.4 \times 10^6 \text{ m}; h = 110\text{m}$$

$$D = (2 \times 6.4 \times 10^6 \times 110)^{1/2}$$

$$= 37500\text{m} = 37.5 \text{ km}$$

$$\text{Population covered} = \text{Population density} \times \pi d^2$$

$$= 4.4 \times 10^6$$

71. A sinusoidal carrier voltage is amplitude modulated by a sinusoidal voltage of 10 kHz to a depth of 30%. Calculate the frequency and amplitude of the two sidebands if the carrier frequency is 10 MHz and its amplitude is 40V.
 (USB = $f_c + f_m = 10.01$ MHz ; LSB = $f_c - f_m = 9.99$ MHz)

72. An audio signal given by $e_m = 30 \sin(2\pi \cdot 2500t)$ volts is used to amplitude modulate a carrier wave given by $e_c = 60 \sin(2\pi \cdot 200,000t)$ volts. Find
 Percent modulation
 Components of modulated wave and
 The amplitude of each side band.
 ($m = E_m/E_c \times 100$; 50% ; 200 kHz ; 197.5 kHz)

73. An amplitude modulated wave is represented as
 $E = 5(1 + 0.6 \cos 6280t) \sin 211 \times 10^4 t$, volts
 What are the 3 minimum and maximum amplitudes of the am wave?
 What frequency components are contained in the modulated wave?
 What are the amplitudes of the components?
 (i) min. amp. = $E_c - mE_c = 2V$; max. amp. = $E_c + mE_c = 8V$;
 (ii) $f_c - f_m, f_c, f_c + f_m$; 335 kHz, 336 kHz, 337 kHz
 $mE_c/2, E_c, mE_c/2$; 1.5 V, 5V, 1.5 V)

74. An FM transmission has a frequency deviation of 18.75 kHz. Find percentage modulation, if it is broadcast
 In the 88.108 MHz band and
 As a sound portion of TV broadcast.
 ($m = (\Delta f)_{\text{actual}} / (\Delta f)_{\text{max}} = 25\%$; 75%)

75. An FM signal has a resting frequency of 100 MHz and the highest frequency of 100.05 MHz when modulated by an audio signal of 5 kHz. Determine
 Frequency deviation
 Carrier swing
 Modulation index
 Percent modulation and
 Lower frequency reached by the EM wave.
 ($\Delta f = 50$ kHz ; CS = $2\Delta f = 100$ kHz ; $m_f = \Delta f / f_m = 10$; $m = (\Delta f)_{\text{actual}} / (\Delta f)_{\text{max}} = 66.67\%$; 99.95 MHz)